



Universal
Literacy

The Dorothy Bonawit Kole School P.S.49

Grades K - 2 | June 2019



A Note from Your Universal Literacy Coach

My name is Crystal Singletary-Stone and I would like to introduce myself as The Dorothy Bonawit Kole School assigned Universal Literacy coach. I have had the opportunity to collaborate with P.S. 49 since November 2018. The Universal Literacy Initiative provides dedicated reading coaches to all NYC public schools who work with kindergarten through second grade teachers to promote students reading on grade level by the end of second grade. With collaboration with your child's school I hope for the next school year to engage in parent workshops around a variety of literacy topics to create home and school connection.



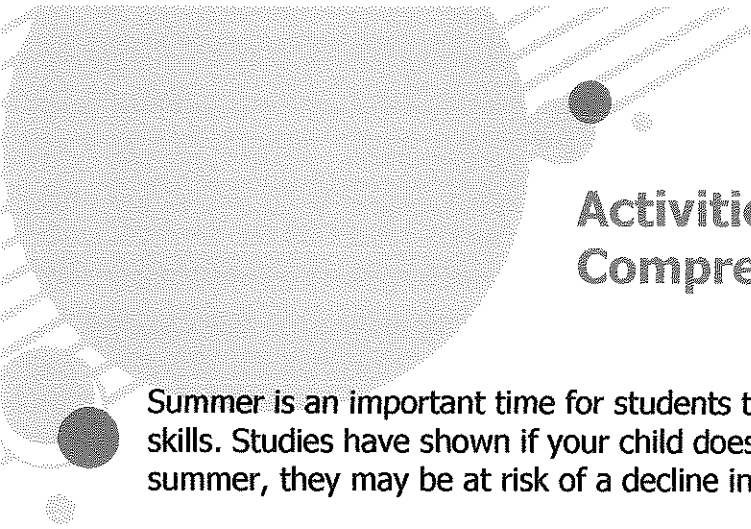

Activities to Strengthen Reading Comprehension

Summer is an important time for students to keep reading and improve their language skills. Studies have shown if your child does not continue to read regularly during the summer, they may be at risk of a decline in their reading ability.

The best ways to keep your child from becoming a "rusty reader" over the summer are:

1. Encourage your children to read books they enjoy for at least 30 minutes per day. Your child will likely be more engrossed in materials they choose themselves than material that is forced on them.
2. Provide incentives for reluctant readers. For example, if your child enjoys basketball, agree to take them to the local court if they do their "daily reading".

3. Make reading a social act. Establish a time during the day when all members of the family gather and read on their own, or take turns reading the same book aloud.
4. Connect your reading to family outings. If you take your kids to an aquarium, consider reading a book about fish or the ocean with them later that day. The outing can help place the reading into a broader context.

There's still time for kids to pick up a book this summer. Take your children to your local library or bookstore and let them pick out a book they're going to love today. The outing can help place the reading into a broader context.

With this newsletter includes various resources for reading comprehension skills that you can use with your child when reading.

"CHILDREN ARE MADE READERS ON THE LAPS OF THEIR PARENTS." by Emilie Buchwald

Website:
www.49online.org

Contact:
718326-2111

Email:
CSingletarystone@schools.nyc.gov

Make Connections

What does that remind you of?

How can you connect this to your own life?

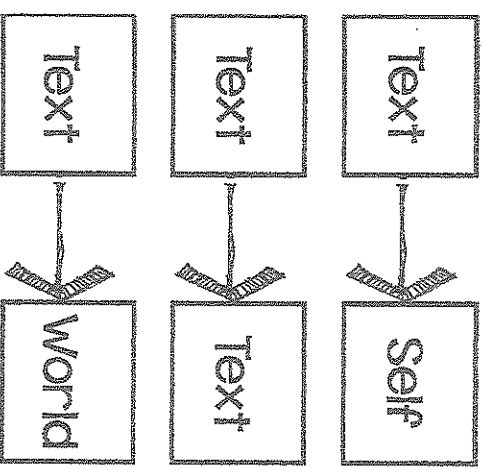

reminds me of a time

when _____.

is like _____ because _____.

Vocabulary

Make Predictions

What will happen next?

Why do you think that will happen next?

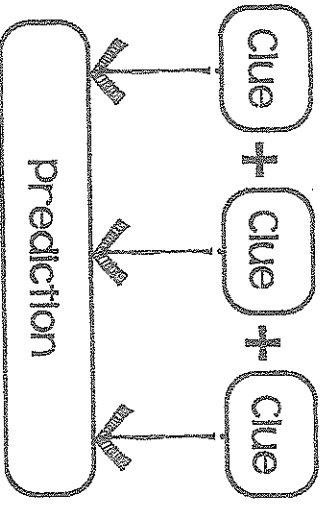

so I think _____.

that _____.

I predict that _____.

because _____.

Vocabulary
based on
predict
prediction

Make Inferences

What inference can you make from the text?

What clues from the text helped you make that inference?

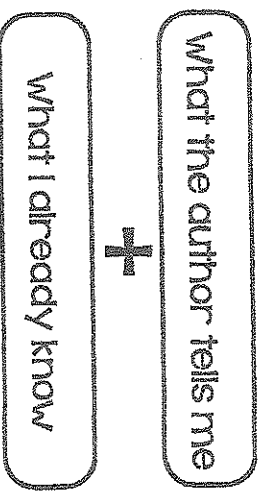

My Inference

The author said _____ and _____.

I know that _____.

so I can infer _____.

Vocabulary
since
consequently
therefore
infer
conclude
indicates
leads me to believe

Ask Questions

What question can you ask about what you read?

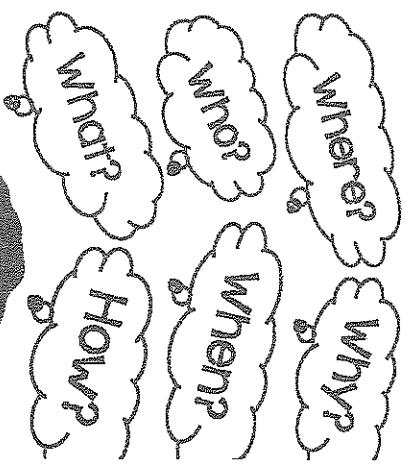

Vocabulary

Identify Plot

What happened in the beginning of the story?

What happened in the middle?

What happened at the end?

Beginning

Middle

End

At the beginning of the story

During the middle of the story

At the end of the story

Vocabulary

Describe Story Structure

Who are the characters?

Where does the story take place?

What is the problem?

How is the problem solved?

Characters

Setting

Problem

Solution

The main characters are _____ and _____.

The setting of the story is _____.

The problem is _____.

The problem is solved when _____.

Vocabulary

Identify Main Idea & Details

What is the passage mostly about?

What details support this main idea?

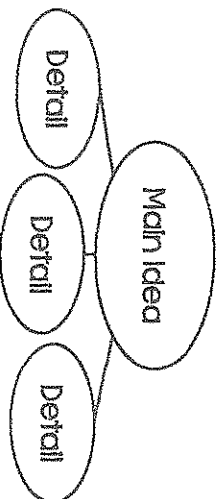

The _____ is mostly about _____.

A detail that supports the main idea is _____.

idea is _____.

Vocabulary

main idea

passage

article

text

example

stated

supported

mainly about

supporting detail

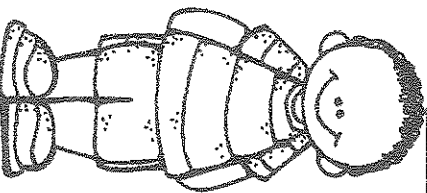

Identify point of View

Who is telling the story?

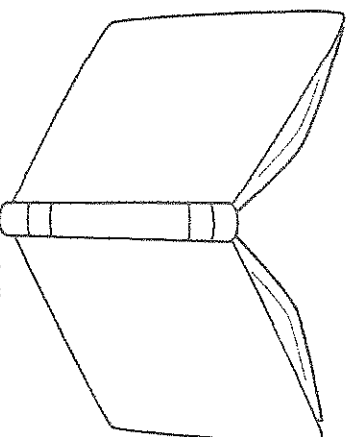
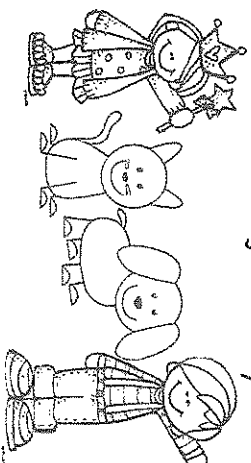

_____ is telling the story.

The narrator is _____.

The story is told from _____.

point of view.

Vocabulary

Determine Author's Purpose

Why did the author write a passage, book, or story?

Did they want to entertain, to inform, to persuade, or to teach?

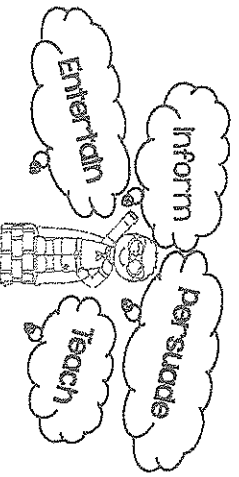

The author wrote

to

Vocabulary

- the passage
- the article
- the text
- inform
- entertain
- persuade
- teach

Determine Important Information

What are the important ideas?
What is essential to know and remember?

Interesting	Amelia Earhart wrote a book telling others about being a pilot.	Important	Amelia Earhart is famous for flying alone across the Atlantic Ocean.
	She helped inspire women to try new things.		Amelia was trying to fly around the world when her plane disappeared.

_____ is important to know.

_____ is important to remember.

Vocabulary

Determine Fact & Opinion

Is that something that can be proved?
Is that something that someone thinks or believes?

Fact	Cats have four legs, whiskers, and they meow. Butterflies go through a life cycle.	Opinion	I like cats! Butterflies are pretty.
------	---	---------	---

_____ is a fact.

_____ is an opinion.

Vocabulary

Monitor Comprehension

Do you understand what you are reading?

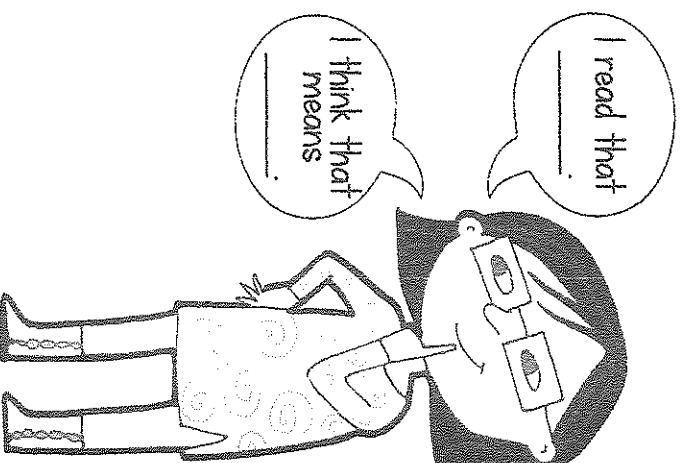

I read that _____

That means _____

Vocabulary

Genres

Realistic Fiction

a fictional story that could really happen in the real world

Fantasy

stories set in a place that does not exist, about people and creatures that could not exist

Fable

a story, usually with animals as characters, that tells a lesson or moral

Poetry

imaginative thoughts, often containing rhythm, imagery and figurative language

Nonfiction

writing about real things, people, events and places

Play

a story written to be performed on a stage

Biography

a nonfiction book or passage about a person's life

Folktale

stories that explain things about life or nature that are told orally over time

Identify Genre

What kind of story is it?

Realistic Fiction

Fantasy

Fable

Poetry

Nonfiction

Play

Biography

Folktale

This story is

Vocabulary

Figurative Language

Metaphor

comparison of two things

Simile

comparison of two things using like or as

Personification

when an object or animal acts like a person

Hyperbole

an extreme exaggeration

Alliteration

repetition of a sound within a group of words

Analogy

shows a similarity between two things; uses something familiar to explain something unfamiliar

Idiom

an expression that means something different than the individual words

Onomatopoeia

words that imitate the sounds of the object or animal

Describe Figurative Language

How does the author use words to imply another meaning or to help you feel an emotion?

